



# DAIRYLAND ELECTRICAL INDUSTRIES

ISOLATE. GROUND. PROTECT.

## The Polarization Cell Replacement (PCR) Technical Literature

### INTRODUCTION

The Polarization Cell Replacement (PCR) is a solid-state device commonly used in conjunction with cathodically protected structures. The PCR is an ideal replacement for electrochemical polarization cells because the solid-state design eliminates the maintenance requirements and the potentially hazardous electrolytes associated with polarization cells. Furthermore, the operating parameters offer a number of distinct advantages. Because the device has a higher DC blocking voltage, one device can often replace two or more polarization cells. The product is easy to apply because its operating parameters are precisely defined.

This product is available in two different versions to most economically accommodate the two different hazardous location listings which are available. In many applications, these products are used in a hazardous location; hence, the reason for hazardous location listings. All model numbers with a PCR prefix are listed for use in Class I, Division 2 hazardous locations and for Zone 2.

All model numbers with a PCRH prefix are listed for Class I, Division 1, hazardous locations. For more information on the PCRH, please visit the [PCRH](#) section on our website, and view the separate PCRH literature.

These products prevent the flow of DC current when the absolute voltage (i.e., the DC plus peak AC voltage) across the terminals is between -3.0 volts and + 1.0 volt while simultaneously providing a grounding (or coupling) path for steady-state AC current, if AC current is present. A symmetrical version, which blocks +/-2.0 volts is available as an option. Custom versions with other voltage blocking levels will be considered upon request. These products also provide over-voltage protection to both lightning and AC fault current.

### Did You Know?

The PCR has been certified by independent laboratories Underwriters Laboratories and Demko for compliance to worldwide standards and codes, and is certified for use in Div 2 and Zone 2 hazardous locations. For more information on certifications and listings, visit [www.dairyland.com](http://www.dairyland.com)



### COMMON APPLICATIONS

#### AC Voltage Mitigation

As an AC mitigation device, the PCR can collapse the steady-state voltage between the connected points to a negligible level by providing continuous AC grounding for pipelines with induced AC while leaving cathodic protection unaffected.

#### Decoupling Electric Equipment Grounding Systems

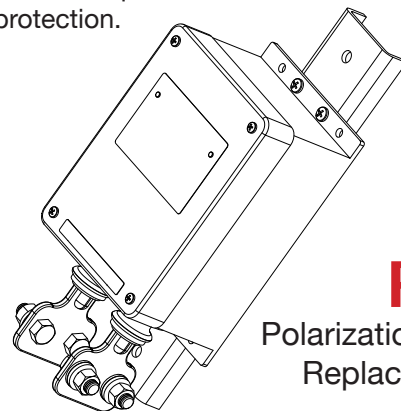
When electrical equipment is mounted on a cathodically protected structure, the PCR can provide DC isolation with fault rated AC continuity. As grounding codes apply, the PCR is listed by UL for meeting the requirements of an effective AC grounding path per U.S. and Canadian electric codes.

#### Insulated Joint Protection

Insulated joints often need over-voltage protection against lightning and AC fault current, and in some cases, steady-state induced AC voltage. Due to the small clearance between opposite sides of the insulated flange, a protective device must provide a low clamping voltage, including the voltage effects of the conductors or bus bars used to connect the product

#### Decoupling from Utility Grounding Systems

When a cathodically protected structure is tied into the site grounding grid, CP values may be unacceptably low, due to the bond between the site grounding system and the power company grounding system. The PCR can be installed by the power company at the transformer, to provide DC isolation and AC grounding between the two systems. This minimizes the CP current requirements and allows acceptable CP voltage for protection.



**PCR**  
Polarization Cell  
Replacement

## PRODUCT OVERVIEW

### AC Fault Current Ratings

Some applications may have conditions where an over-voltage device such as the PCR is subject to fault current. For this reason, the PCR was designed to have AC fault current carrying capability. The PCR will limit the voltage between its connection points to less than 10 volts AC under the maximum fault current ratings listed below.

Four different fault current ratings are offered at 60Hz and 50Hz with the following current-time relationship:

AC Fault Current Ratings (Amps AC-RMS Symmetrical)				
60 Hz Cycles	3.7kA	5kA	10kA	15kA
1	6500	8800	20000	35000
3	5000	6800	15000	27000
10	4200	5700	12000	21000
30	3700	5000	10000	15000
50 Hz Cycles	3.7kA	5kA	10kA	15kA
1	6500	8800	19000	33000
3	5000	6800	14000	25000
10	4200	5700	11000	20000
30	3700	5000	9000	14000

Note: Select a PCR fault current rating that encompasses the fault current available. For more information on sizing for available fault current, view our web article: [Determining AC Fault Current](#).

### Steady-State AC Current Ratings

This rating represents the maximum steady-state AC current that is allowed to flow through the device while still blocking the flow of DC current. Two ratings are available for the PCR.

The table represents maximum values. As the DC voltage approaches the maximum blocking voltage rating selected, the allowable steady-state AC current is reduced as shown in Figures 1 and 2.

Steady-State Current Ratings (Amps AC-RMS Symmetrical) 50/60 Hz Ratings		
Ambient Temp	Standard 45A Rating	Optional 80A Rating
20°C	50A	90A
65°C	40A	70A

There are a number of applications where a PCR may be required to block DC while simultaneously carrying steady-state AC current. For example, when a pipeline is in the same corridor as an electrical transmission line, steady-state AC voltage

is often induced on the pipeline. The PCR can mitigate this voltage by providing a low AC impedance path for AC current to flow to ground while simultaneously preventing the flow of DC current.

The steady-state AC impedance of the PCR at 60 Hz is 9.8 milliohms for the standard 45 ampere rating and 4.9 milliohms for the optional 80 ampere rating. At 50 Hz, the comparable impedances are 11.9 milliohms for the standard 45 ampere rating and 5.8 milliohms for the optional 80 ampere rating. Under an AC fault or lightning current condition, these impedances momentarily become virtually zero. For more information on steady-state current view our web article: [Measuring Steady-State AC Current](#)

### DC Blocking Voltage Rating

The standard, and most commonly specified, PCR model has an asymmetrical voltage blocking rating of -3.0 volts to +1.0 volt. Either model can also be furnished with a symmetrical voltage blocking rating of +/- 2.0 volts. Other voltage blocking ratings will be considered upon request.

The reasons for symmetrical and asymmetrical choices are best described with an example. If the PCR is used to provide over-voltage protection for an insulated joint and both sides of the joint are cathodically protected, the DC voltage across the joint will be the difference in voltage between the two cathodic protection systems, normally near zero volts. For this application it is desirable to select the symmetrical +/- 2.0 volt blocking rating. In the event that the cathodic protection system is OFF on one side of the joint, the device can block  $2.0 V_{DC}$  in either direction.

If one side of the insulated joint is cathodically protected and the other side is grounded, then it is preferable to select the asymmetrical version which blocks from -3.0 volts to +1.0 volt since one side has been shifted to a more negative voltage. Whenever one side is referenced to ground, the asymmetrical version is suggested because the CP voltage is situated in the center of the threshold voltage range.

### Lightning Surge Current Rating

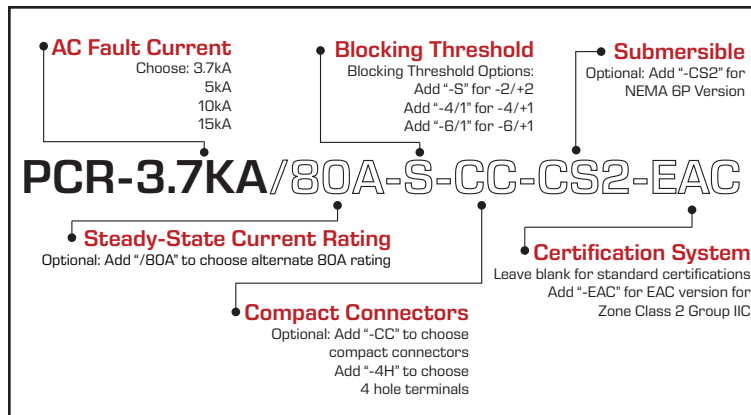
All models have the same lightning surge current rating which is shown in the following table.

Lightning Surge Current Rating All PCR Models
Peak Amperes: 100,000
Note: 8x20 microsecond waveform

### Keep the Conductors Short!

The PCR is designed to keep the voltage between the device terminals to a limited value. During lightning conditions, a more important factor than the PCR voltage clamping capability is the voltage developed in the conductors or bus used to attach the device. Use low inductance bus bars or conductors ideally less than 6 inches (150 mm) long for best results. More information on conductor length is available at [www.dairyland.com](http://www.dairyland.com).

## ORDERING INSTRUCTIONS



**NOTE:** The EAC version is a separate product from standard models, with a Cyrillic nameplate and instruction manual, and references GOST standards only. To purchase, order model with "EAC" suffix. See separate Russian/English EAC manual.

## FEATURES AND CERTIFICATIONS

### Certifications

Underwriters Laboratories (UL) has listed the PCR as meeting the criteria for "an effective grounding path" as defined in Section 250.2 and 250.4(A)(5) of the U.S. National Electrical Code (NFPA 70), thereby enabling its use as an AC grounding device. The PCR is also C-UL listed in Canada as meeting the criteria for "an effective grounding path" as defined in C22.1-12, Section 10-500.

The PCR is also listed by UL as meeting:

- The requirements of a DC isolating/AC coupling device suitable for the isolation of objectionable DC current from cathodically protected systems to ground as defined in NFPA 70 Article 250.6(E) and C22.1-12 Section 10-806.
- An over-voltage protective device, having been tested to the applicable requirements of ANSI C62.11.

Listings specific to hazardous locations are summarized as follows:

The PCR is listed by Underwriters Laboratories (UL) for use in hazardous locations in accordance with NFPA 70 (U.S. National Electric Code), Articles 500-505 for Class I, Division 2, Groups A, B, C, and D. The applicable standard to which the PCR is listed is ANSI/ISA 12.12.01-2011 which deals with non-sparking products to meet Class I, Division 2 requirements. The PCR is also C-UL listed to the above classifications per Canadian code C22.2 No. 213-M1987 (R2008).

The PCR has been certified to ATEX Directive 94/9/EC and IECEx requirements for use in Zone 2, Group IIC hazardous locations by UL/DEMKO to: EN 60079-0:2012, EN 60079-15:2010, IEC 60079-0: 6th Ed, IEC 60079-15: 4th Ed.

The EAC version of the PCR, available by ordering a PCR model with an "-EAC" suffix, is certified to the EAC requirements of the Customs Union (Russia, Kazakhstan, etc) for use in Zone Class 2, Group IIC hazardous locations by NANIO-CCVE to: GOST R IEC 60079-15-2010, GOST R IEC 60079-0-2011.

## Solid-State Design

The PCR is built with proven solid-state components which have an instantaneous response with respect to voltage, thereby initiating voltage clamping immediately when the voltage attempts to exceed the blocking level selected.

### Fail-Safe

An important safety feature for the PCR is that if subject to AC fault current or lightning surge current in excess of rating such that failure occurs, failure will occur in the shorted mode. In the shorted mode, the unit can carry greater than rated fault current or lightning surge current and still provide an effective grounding (or conducting) path.

### Enclosure

The PCR enclosure is made of a light gray fiberglass-reinforced polyester material suitable for outdoor non-submersible applications and is rated NEMA 4X (comparable to IP 66). Optionally, the PCR can be supplied as a submersible device with the same dimensions rated NEMA 6P (comparable to IP68). The optional submersible version of the PCR must not be installed such that it may be submerged in freezing conditions.

### Terminals

Two-hole spade terminals are standard, but compact connectors and 4 hole NEMA terminals are available. Compact connectors are recommended where necessary to insulate the connections to the PCR after installation (for example, with a user furnished heat-shrink sleeve). Add "CC" to the end of any model number only if compact connectors are required, or "4H" for 4 hole terminals.

PCR terminals have preinstalled 1/2" stainless hardware (bolts, nuts, washers). See [Accessories](#) for various attachment options.

### Examples:

PCR-10KA (Standard connector)  
PCR-10KA-CC (Compact connector)  
PCR-15KA-4H (4 hole terminal)

### Polarity / Electrical Connection

Polarity marks (+) and (-) are provided near the terminals to aid in proper installation. Connect the (-) to the structure with CP or more negative structure and the (+) to the grounded, or more positive, system.

### Size and Weight

Refer to outline drawings for dimensional data. Packaged weight varies from approximately 12-22 pounds (5.5-10kg) depending on model selected.

### Number of Operations

Virtually unlimited under maximum ratings, provided the operations are not immediately repetitive.

### Energy Requirements

None. The devices are totally passive.

**Ambient Temperature**

-45° C to +65° C

**MOUNTING OPTIONS**

The PCR is made to mount on a flat surface (e.g., a wood post, unistrut, panel) with two 3/8" (≈10mm) diameter bolts furnished by user; however, a number of optional mounting methods and accessories are available for specific applications.

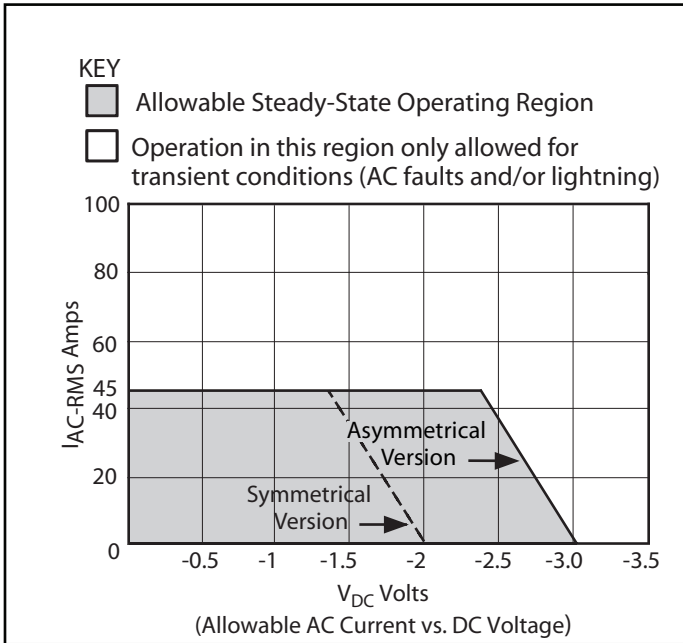
**Mounting Accessories**

Numerous mounting accessories are available from Dairyland to aid in the proper installation of the PCR. Detailed accessory information, including complete installation instructions are available on the Dairyland website here: [Dairyland Accessories](#)

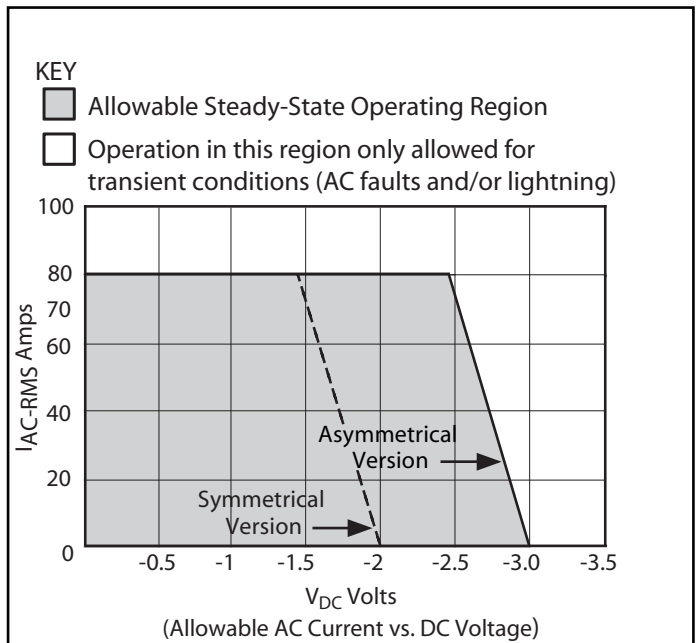
**Specific Installation Guidance**

The Dairyland website contains detailed information on the installation methods specific to a given application. For wiring diagrams and/or application guidance, see [Dairyland Applications](#).

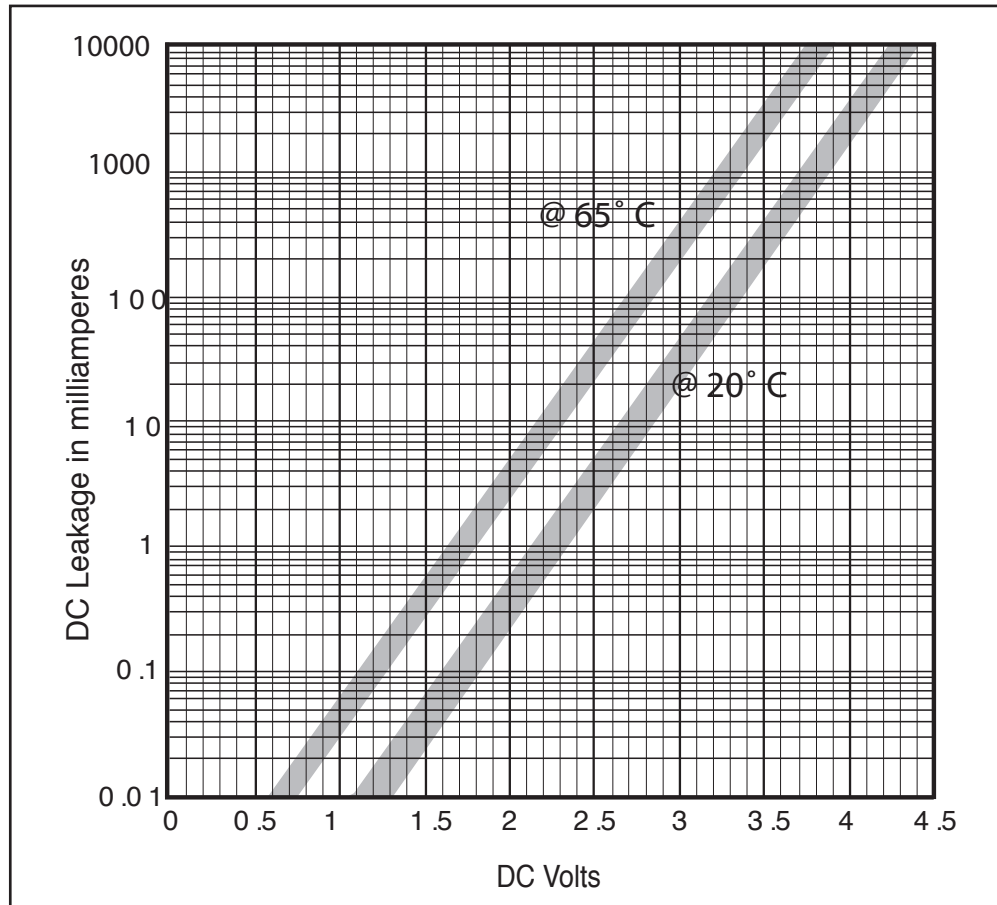
**FIGURE 1** PCR Operating Characteristics @ 43°C  
(Standard 45A @ 50/60 Hz)

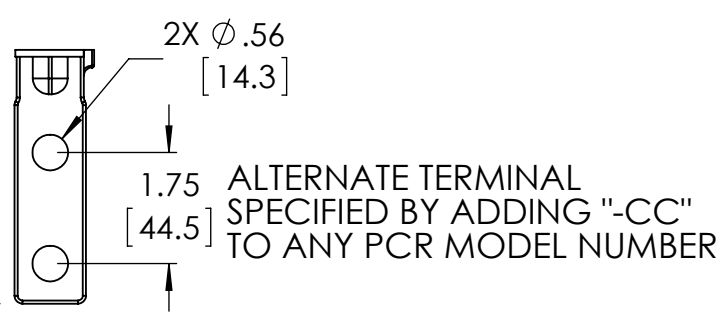
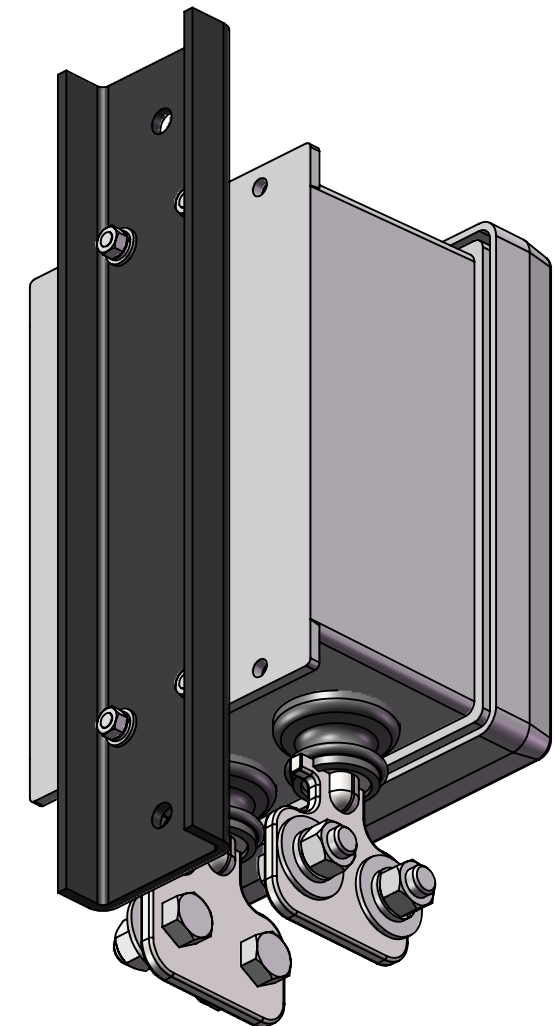
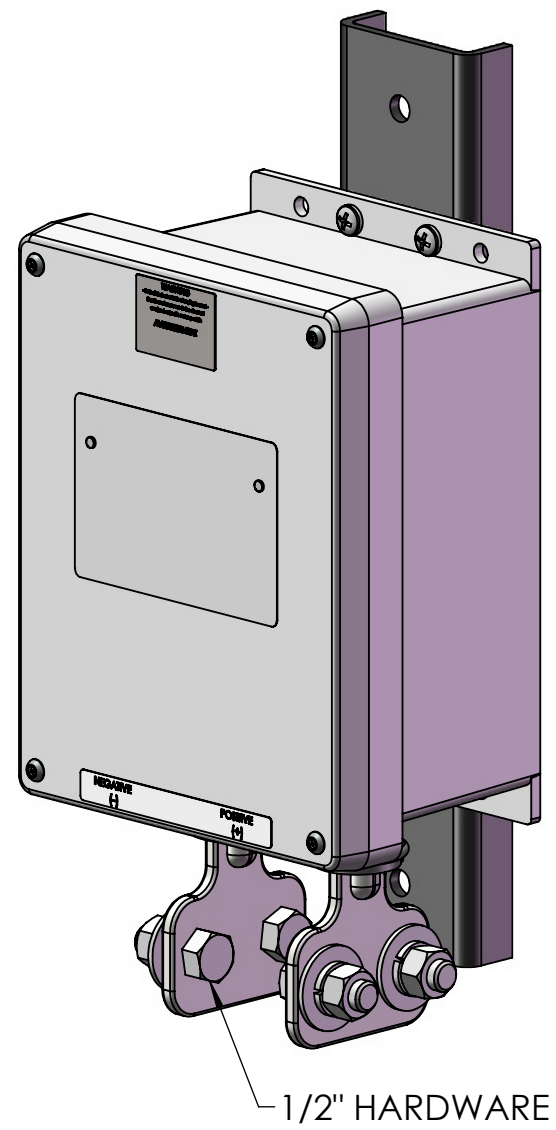
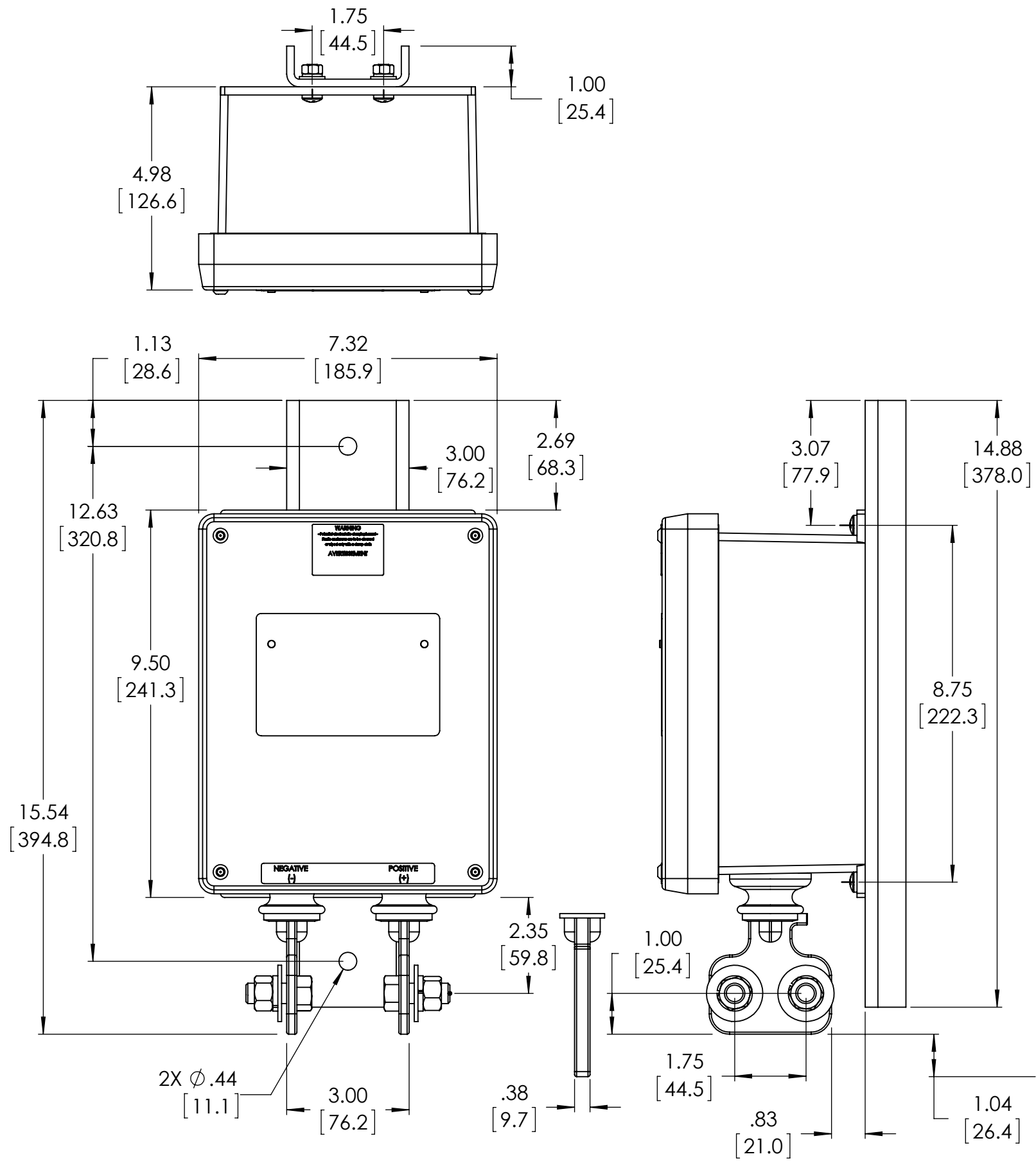


**FIGURE 2** PCR Operating Characteristics @ 43°C  
(Optional 80A @ 50/60 Hz)



**FIGURE 3** DC Voltage vs. DC Leakage Current  
(Standard Asymmetrical PCR with -3V / +1V Blocking Voltage)





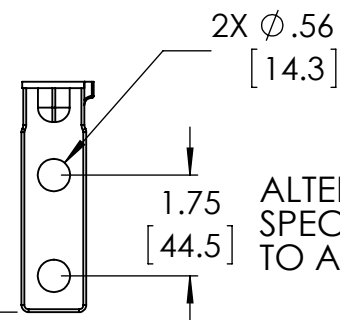
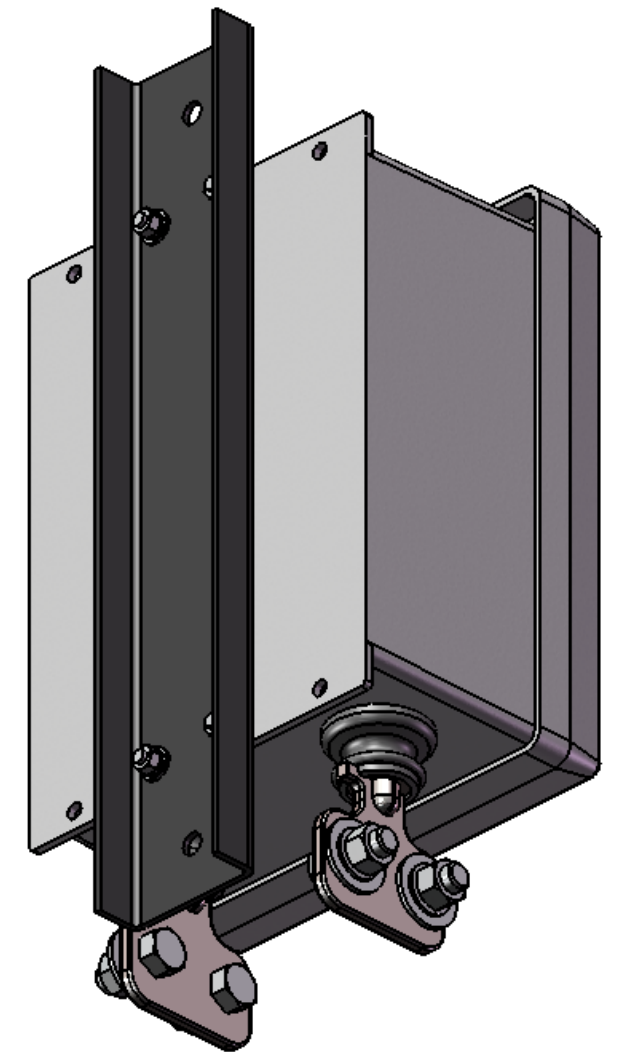
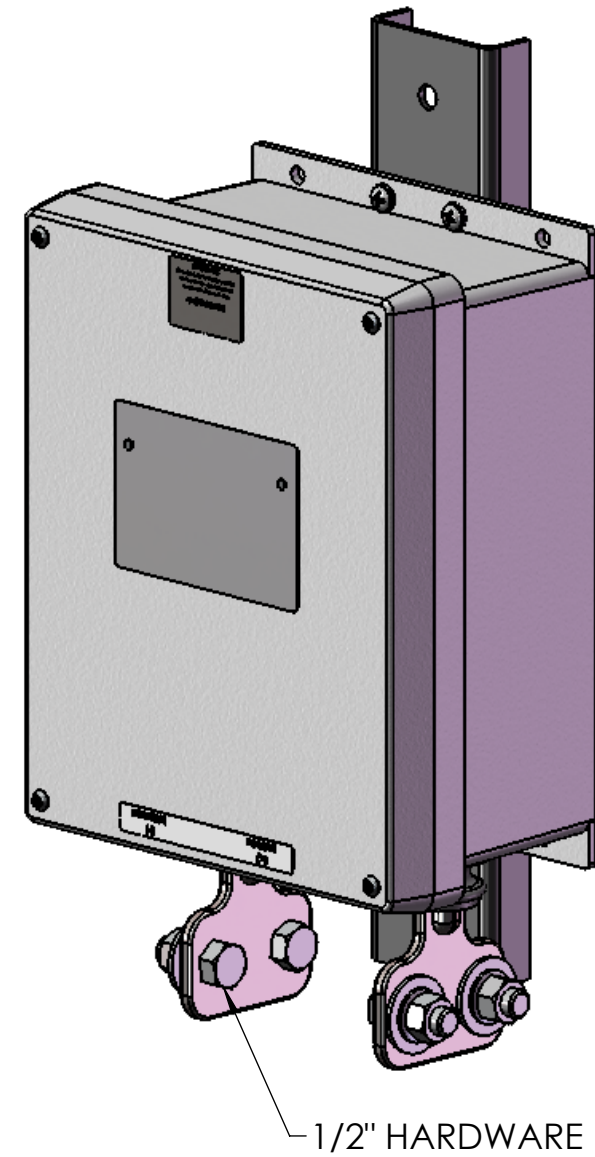
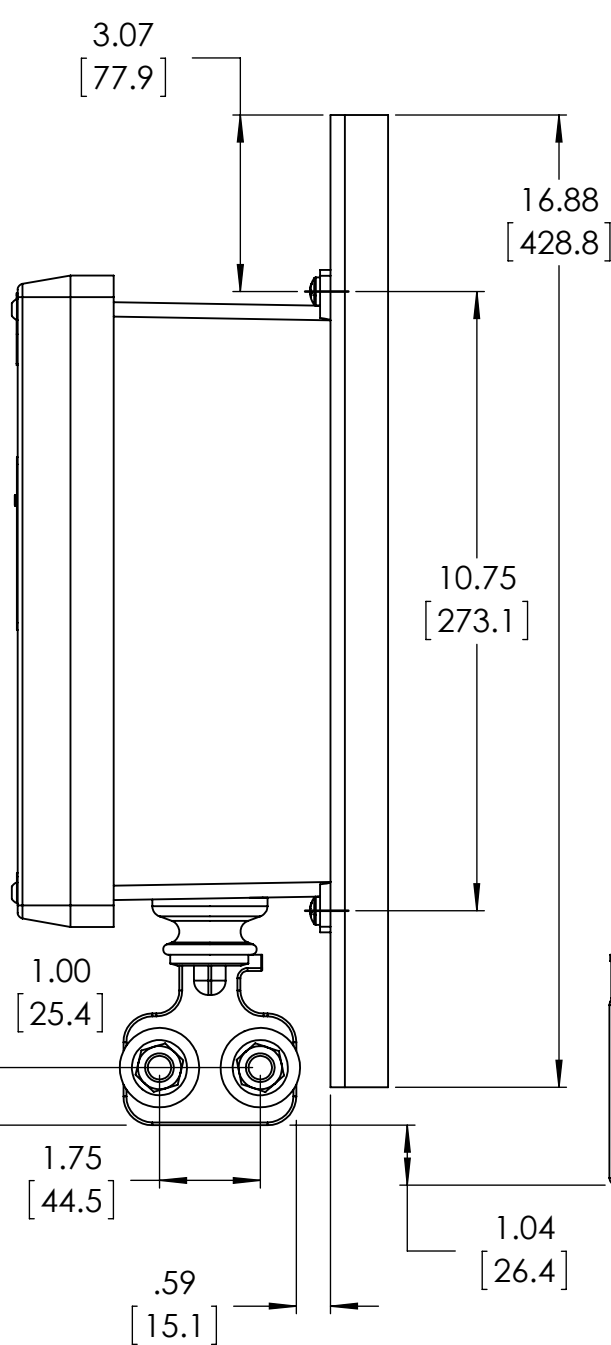
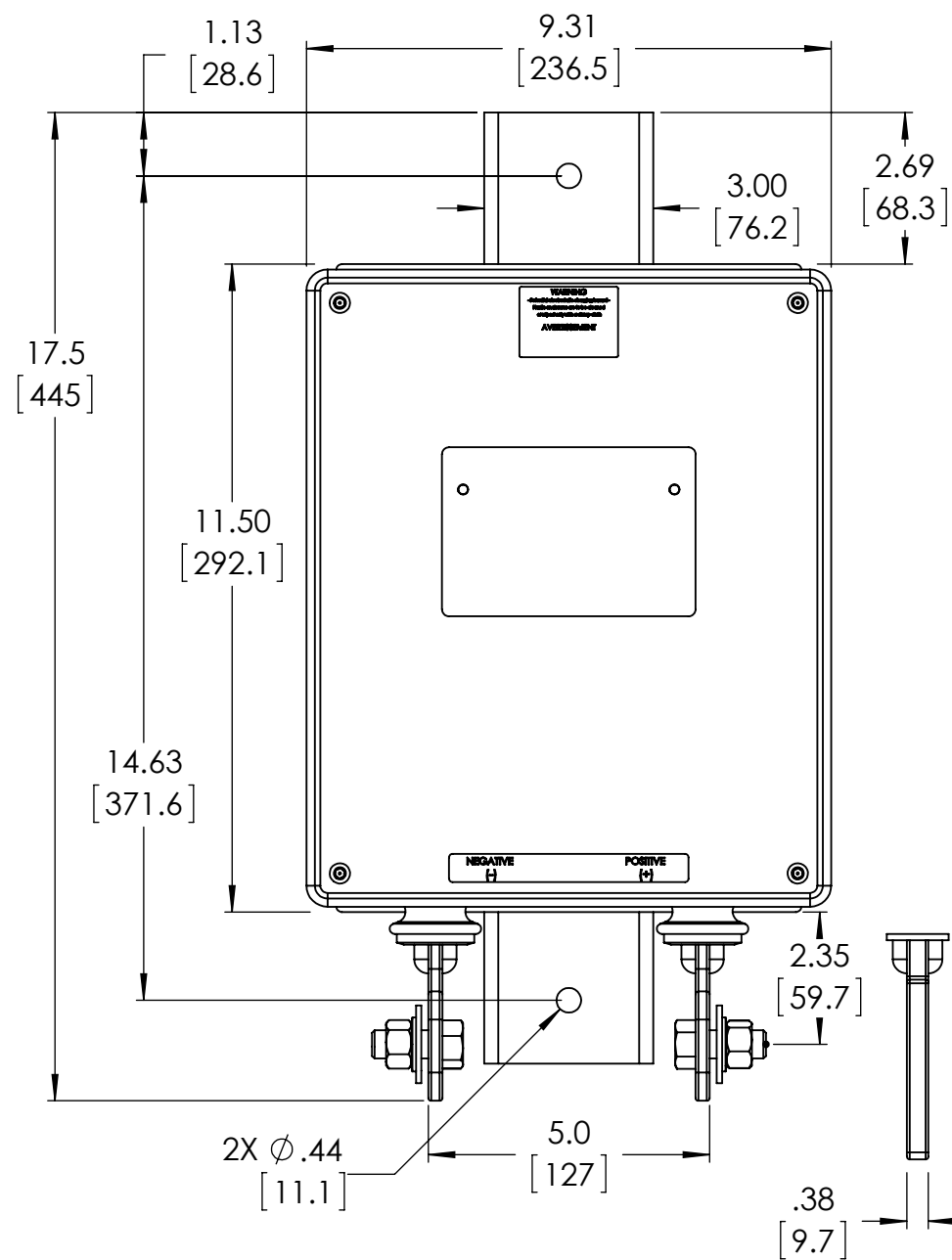
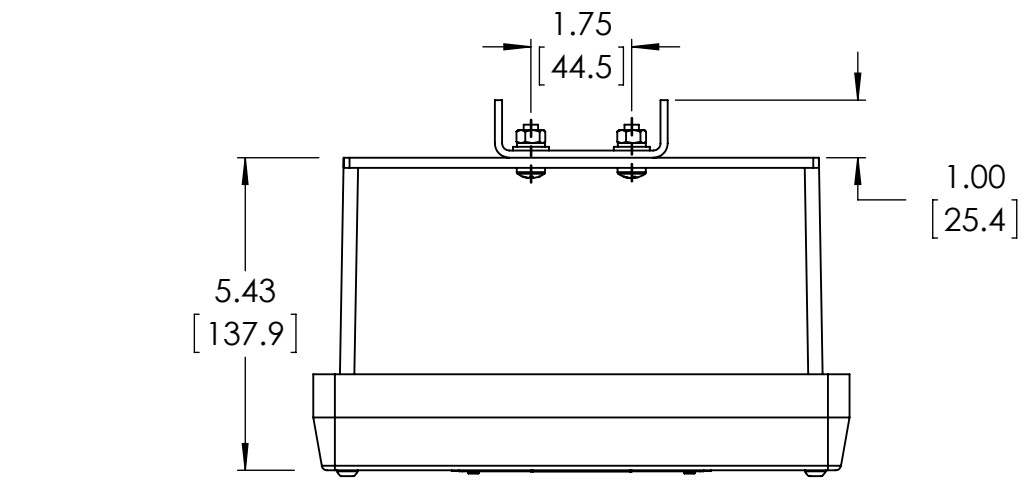
ANSI Y14.5M 1994 APPLIES

UNLESS NOTED  
 UNITS: INCHES  
 3-PLACE:  $\pm$ .005  
 2-PLACE:  $\pm$ .015  
 1-PLACE / FRAC:  $\pm$ .03  
 ANGULAR:  $\pm$ 1



DAIRYLAND  
 ELECTRICAL  
 INDUSTRIES, INC.  
 P.O. BOX 187  
 STOUGHTON,  
 WI 53589  
 608-877-9900  
 DAIRYLAND.COM

DESCRIPTION				
PCR 3.7KA THRU 10KA OUTLINE DRAWING				
DOCUMENT #	REV	DATE DRAWN	DWG SIZE	DATE APPROVAL
100060	A	2014-06-20	B	
SCALE	DRAWN	SHEET	OF	DWG APPROVAL
1:3	JPW	1	1	



ALTERNATE TERMINAL SPECIFIED BY ADDING "-CC" TO ANY PCR MODEL NUMBER

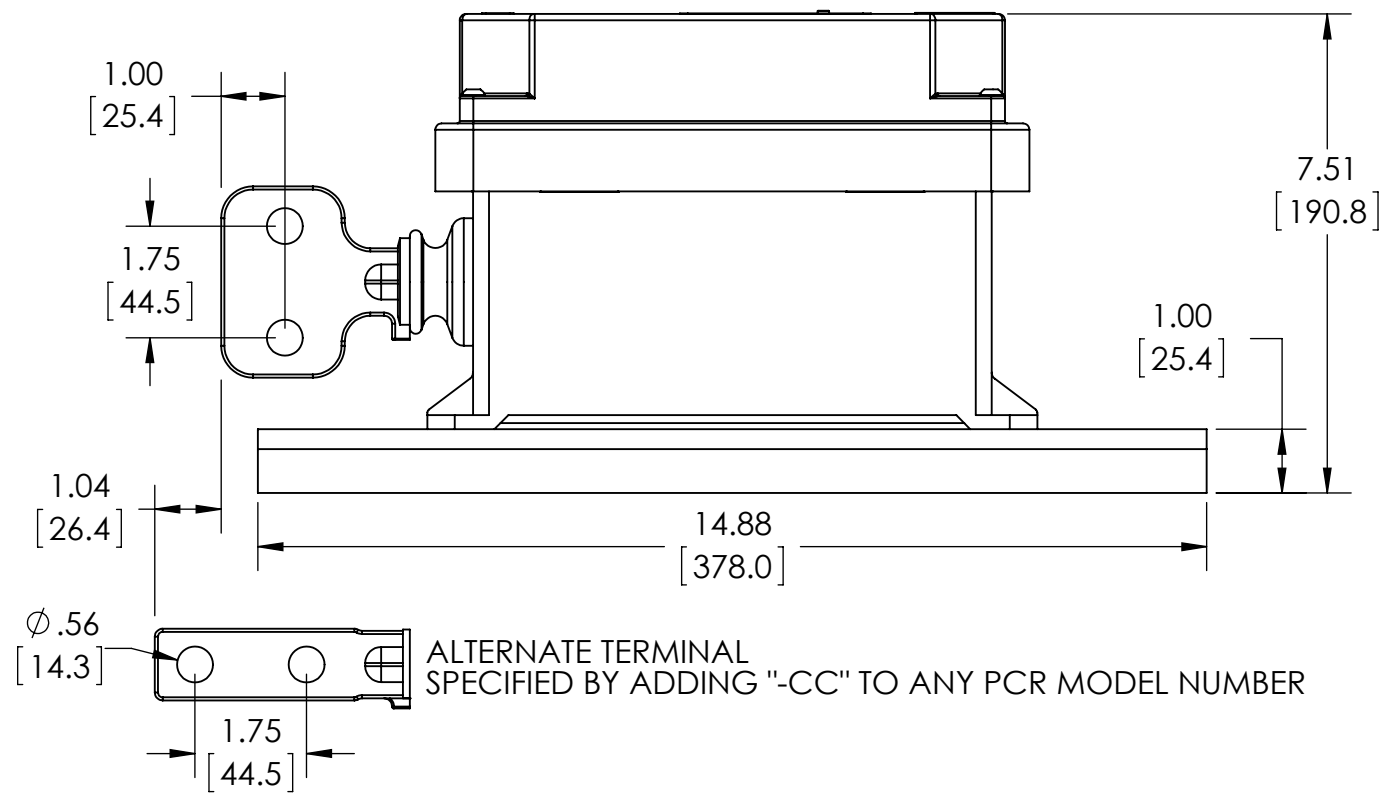
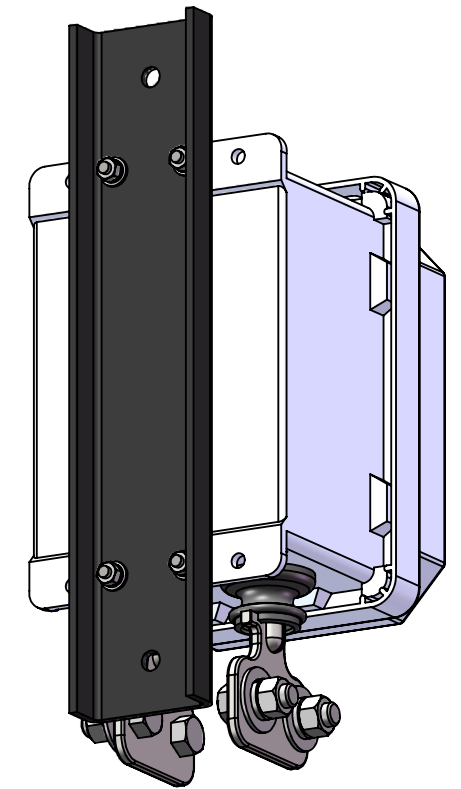
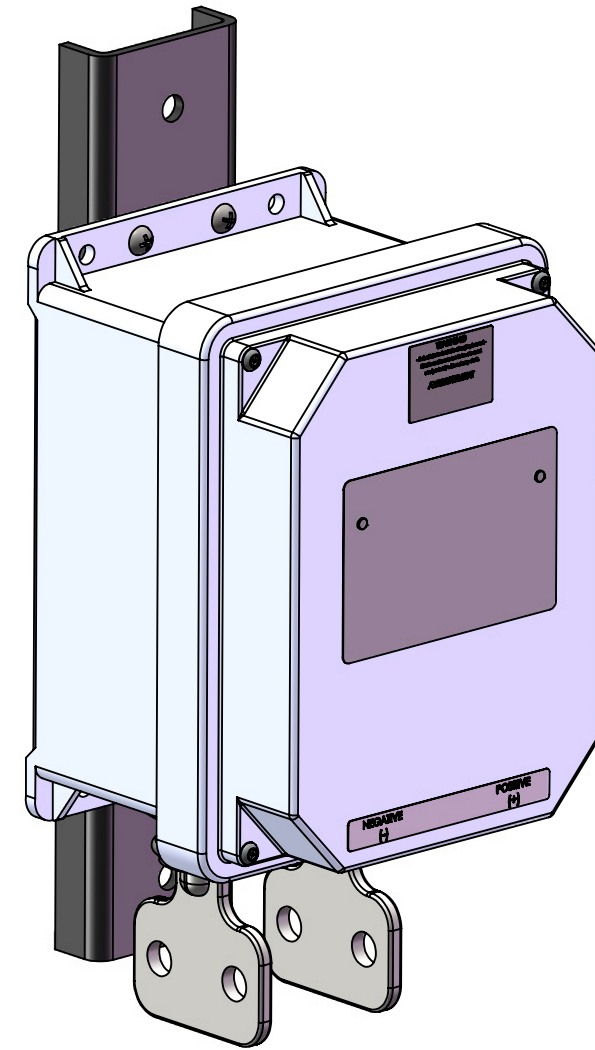
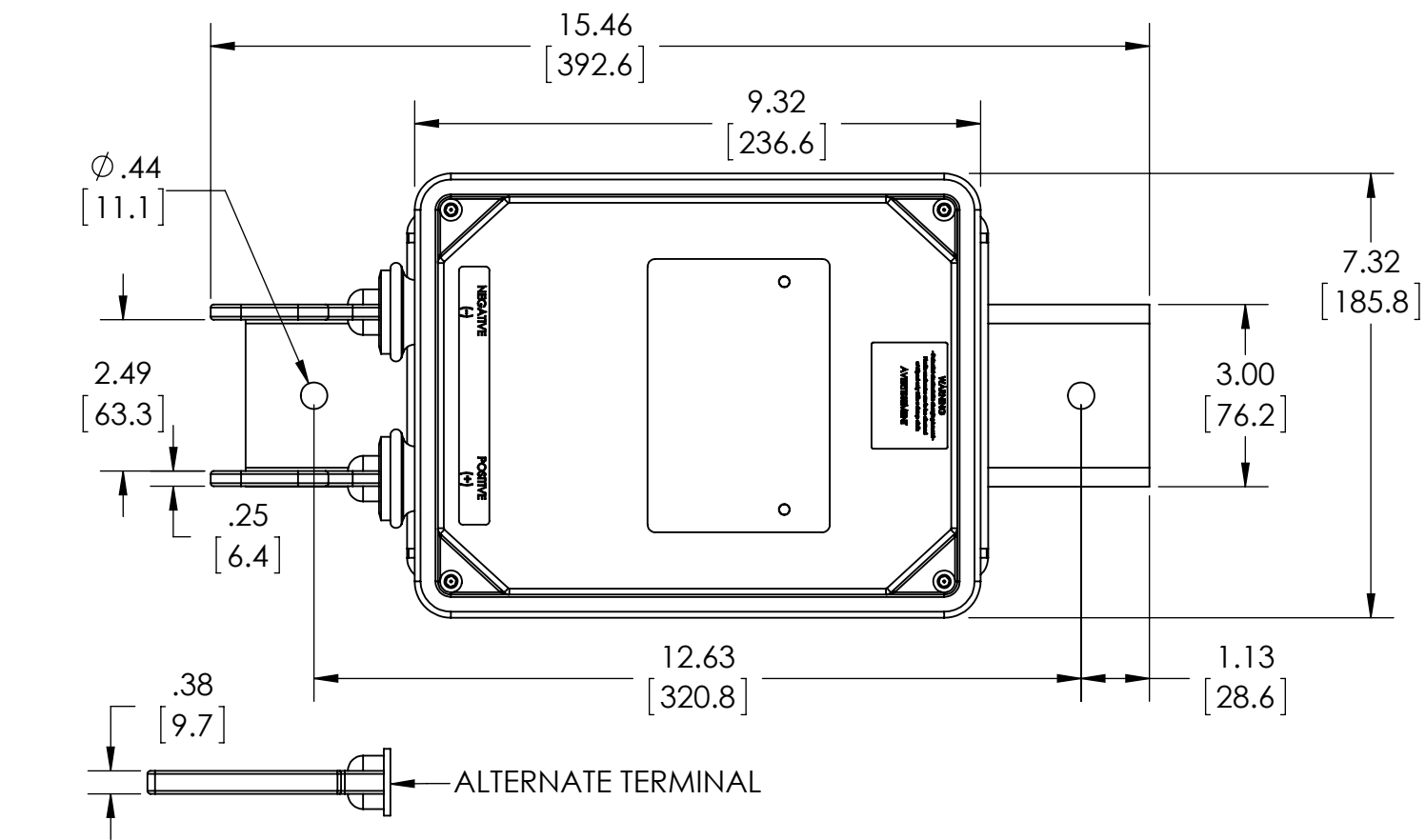
ANSI Y14.5M 1994 APPLIES  
 UNLESS NOTED  
 UNITS: INCHES  
 3-PLACE: ±.005  
 2-PLACE: ±.015  
 1-PLACE / FRAC: ±.03  
 ANGULAR: ±1



DAIRYLAND ELECTRICAL INDUSTRIES, INC.  
 P.O. BOX 187  
 STOUGHTON, WI 53589  
 608-877-9900  
 DAIRYLAND.COM

DESCRIPTION  
 PCR-15KA OUTLINE DRAWING

DOCUMENT #	REV	DATE DRAWN	DWG SIZE	DATE APPROVAL
100085	A	2015-08-18	B	
SCALE 3:10	DRAWN: JPW	SHEET: 1 OF 1	DWG APPROVAL:	



APPLIES TO MODELS:  
PCR-3.7KA/80A, PCR-5KA/80A and PCR-10KA/80A

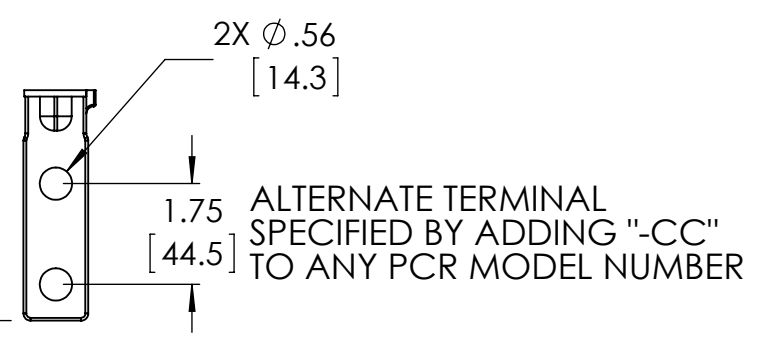
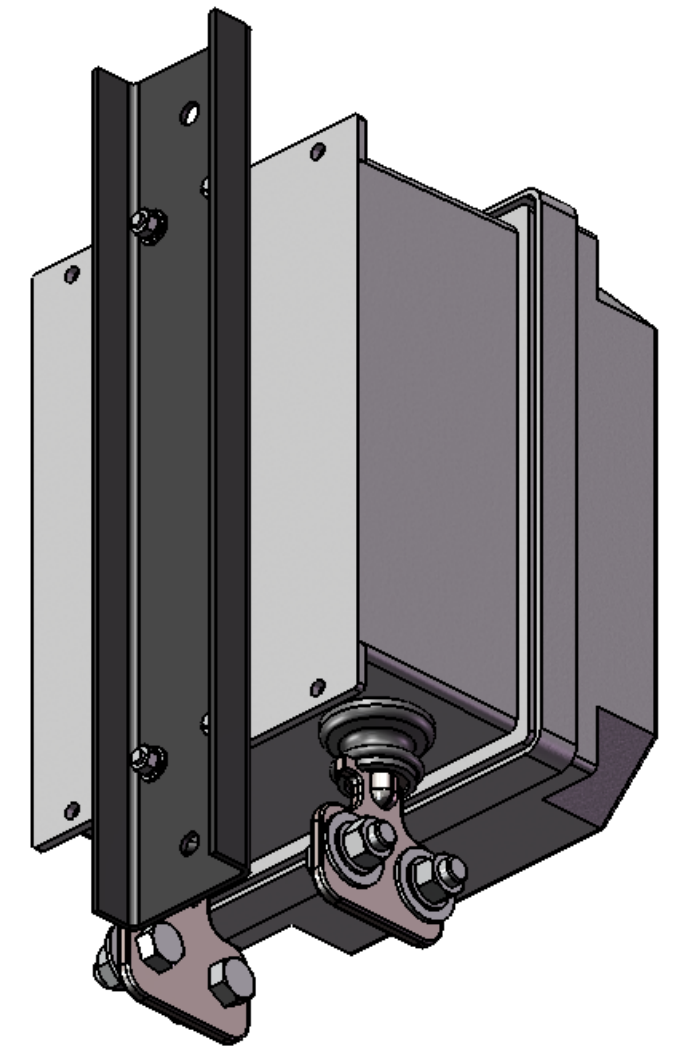
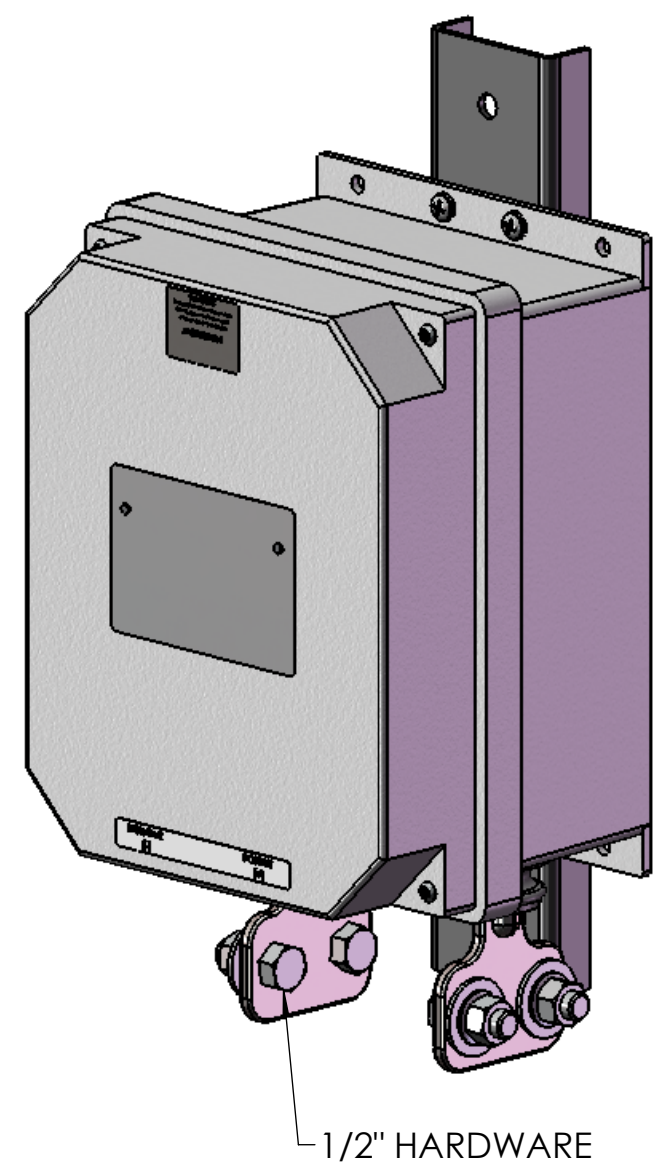
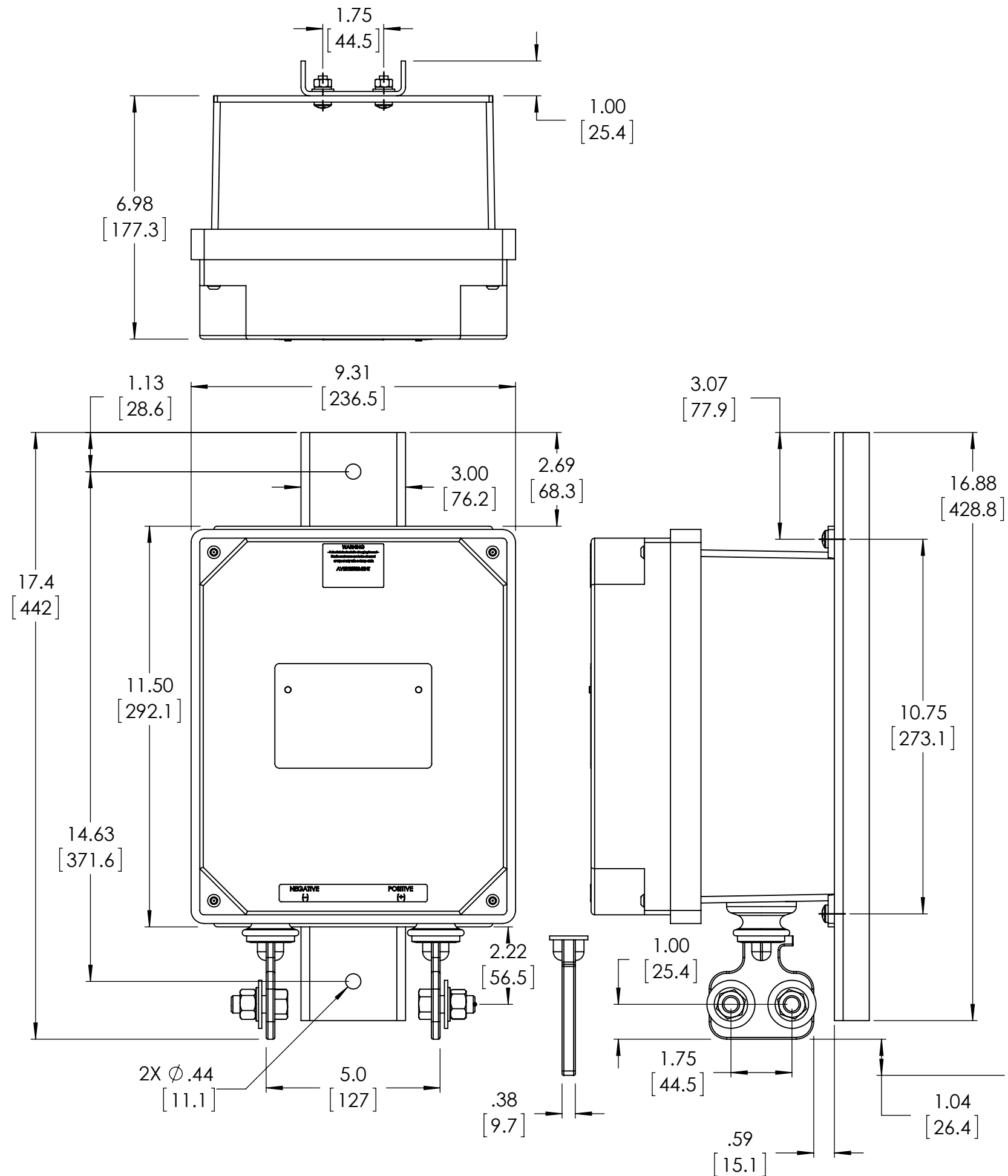
ANSI Y14.5M 1994 APPLIES  
UNLESS NOTED  
UNITS: INCHES  
3-PLACE: ±.005  
2-PLACE: ±.015  
1-PLACE / FRAC: ±.03  
ANGULAR: ±1



**DAIRYLAND  
ELECTRICAL  
INDUSTRIES, INC.**  
P.O. BOX 187  
STOUGHTON,  
WI 53589  
608-877-9900  
DAIRYLAND.COM

DESCRIPTION PCR 3.7KA THRU 10KA-80A OUTLINE DRAWING				
DOCUMENT # 100081	REV A	DATE DRAWN 2015-05-29	DWG SIZE B	DATE APPROVAL 2015-06-02
SCALE 1:3	DRAWN: JPW	SHEET: 1 OF 1	DWG APPROVAL: TC	





ANSI Y14.5M 1994 APPLIES  
 UNLESS NOTED  
 UNITS: INCHES  
 3-PLACE:  $\pm$ .005  
 2-PLACE:  $\pm$ .015  
 1-PLACE / FRAC:  $\pm$ .03  
 ANGULAR:  $\pm$ 1



DAIRYLAND  
 ELECTRICAL  
 INDUSTRIES, INC.  
 P.O. BOX 187  
 STOUGHTON,  
 WI 53589  
 608-877-9900  
 DAIRYLAND.COM

DESCRIPTION PCR-15KA/80A OUTLINE DRAWING				
DOCUMENT # 100087	REV A	DATE DRAWN 2015-08-17	DWG SIZE B	DATE APPROVAL
SCALE 3:10	DRAWN: JPW	SHEET: 1 OF 1	DWG APPROVAL:	